

RD007 - Applicant Guide to Assessment and approval of new Robust Details

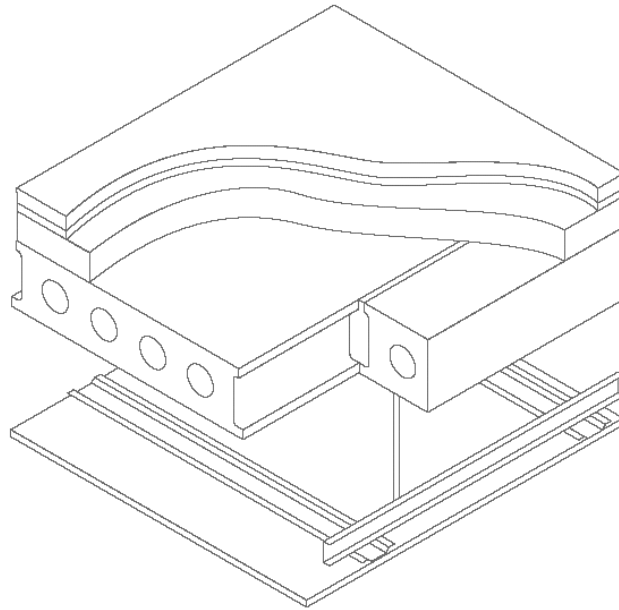

1	Introduction	3
2	Process checklist	5
3	Pre-submission planning	7
3.1	Generic or Proprietary Full Candidate Robust Detail (CRD)	7
3.2	Amend an Existing RD rather than apply for a Full CRD	7
3.3	Testing Considerations	7
3.4	Assessment Criteria	8
3.5	Unusual or Innovative Designs	8
4	Stage A	9
4.1	Stage A process	9
4.2	Application and Stage A submission	9
4.3	Stage A assessment	10
5	Stage B	11
5.1	Stage B process	11
5.2	Stage B testing	11
5.3	Stage B test results	12
5.4	Stage B assessment	12
6	Stage C	13
6.1	Issue and publication of new/amended RDs	13
7	Frequently Asked Questions	14
7.1	Testing	14
7.2	Assessment process	14
7.3	Financial	15
7.4	The Part E Robust Details Scheme	16

1 Introduction

This is the process you need to follow if you want to establish a new Robust Detail or amend an existing one. It involves design assessments, site inspections and acoustic testing. We can only approve and issue your proposed new Robust Detail or amendment where it meets the Robust Details Part E scheme requirements. The process has three simple stages:

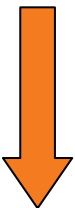
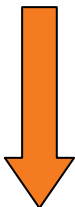
- Stage A** You make an application which includes design details and the first batch of acoustic test results. We assess the acoustic performance and robustness of your design. If the assessment is successful your 'candidate' Robust Detail (CRD) can progress to Stage B.
- 
- Stage B** You submit the remainder of the required test results. We assess the acoustic performance and robustness of your design taking account of all the test results. If the assessment is successful we then approve your design, and your application can progress to Stage C. We will also assign an entitlement to Code for Sustainable Homes credits if appropriate.
- 
- Stage C** We publish the new Robust Detail or amendment and make it available for use by builders and developers to demonstrate compliance with Requirement E1 of The Building Regulations (England and Wales); and where applicable to gain credits for the Code for Sustainable Homes.

Before doing any testing or preparing your application, we recommend that you contact us and, if necessary, arrange a meeting so that we can discuss your proposals and answer any questions you may have. By fully understanding the process and us understanding your design, we will be able to provide appropriate advice; and you will be better placed to identify a cost-effective test plan.

You can contact us on 0870 240 8209 or technical@robustdetails.com.

2 Process checklist

Please use this checklist to help you to complete the process and avoid delays.

Pre-submission planning (Section 3)	Tick
Read through the applicant guide	<input type="checkbox"/>
Contact RDL to discuss application	<input type="checkbox"/>
Establish your testing strategy and programme	<input type="checkbox"/>
Stage A (Section 4)	Tick
Arrange for & carry out Stage A testing in accordance with doc. TR01	<input type="checkbox"/>
Test results comply with performance requirements	<input type="checkbox"/>
Complete and sign the Test Results Form (Form A2)	<input type="checkbox"/>
Complete the application form, including payment	<input type="checkbox"/>
Stage B (Section 5)	Tick
Receive notification from RDL that Stage A assessment successful	<input type="checkbox"/>
Pay fee to RDL for Stage B	<input type="checkbox"/>
Arrange for Stage B testing in accordance with document TR01	<input type="checkbox"/>
Notify RDL in advance, of test sites, dates and test bodies to be used	<input type="checkbox"/>
Testing completed and in accordance with document TR01	<input type="checkbox"/>
Test results comply with performance requirements	<input type="checkbox"/>
Complete and sign Test Results Form (Form A2) for each site	<input type="checkbox"/>
Submit test results including documents listed in Section 5.3	<input type="checkbox"/>
Stage C (Section 6)	Tick
Receive notification from RDL that Stage B approval has been granted	<input type="checkbox"/>
Pay fee to RDL for Stage C	<input type="checkbox"/>
Provide RDL with any further information for publication	<input type="checkbox"/>

3 Pre-submission planning

You can apply for a Candidate Robust Detail (CRD) in a number of ways:

3.1 Generic or Proprietary Full Candidate Robust Detail (CRD)

Generic RDs are capable of being adequately specified without reference to any branded products or systems. Typically, generic applications tend to be submitted mainly by trade associations and builders.

Proprietary RDs are those that, in our view, are not capable of being adequately specified without reference to one or more named or branded system or unique product of a specific manufacturer.

3.2 Amend an Existing RD rather than apply for a Full CRD

It is possible to make an application to amend an existing robust detail. For example, you can submit an application for a new flanking condition for use with an existing RD specification. Applications to amend an existing RD follow the same process as applications for new RDs although less testing is usually required (see document TR01 “Test and Performance Requirements”). However, we will only process applications to amend an existing proprietary RD type-specification if you are the original proposer or you gain the approval of the original proposer.

3.3 Testing Considerations

We recommend that you contact us at the design stage to discuss your application and the options that might be open to you before you do any testing. For example, in some cases, it **may** be possible to use an alternative flanking condition to test structures which could then enable us to increase the scope of the final published specification.

Once you have considered your options, decide upon your testing strategy. All testing needs to be planned and organised by you, and it is crucial that you read our Test and Performance Requirements first (please see document TR01) in order to formulate a cost-effective testing programme.

3.4 Assessment Criteria

Our assessment decisions will be based on two factors: acoustic performance and **'robustness'**.

- The acoustic performance will be assessed on the basis of the test data.
- In order to be considered as robust, the design must, in the judgement of our independent technical experts, be practical to build on site and reasonably tolerant to workmanship variations. They will also take into account other issues such as number of components and ease of inspection.

We strongly advise you to consider the robustness aspect at the outset. And if necessary, contact RDL for further advice and guidance.

3.5 Unusual or Innovative Designs

If your application incorporates any new, unusual or innovative materials, designs or methods of construction, we may ask you for an independent assessment by an authoritative product approval organisation.

4 Stage A

4.1 Stage A process

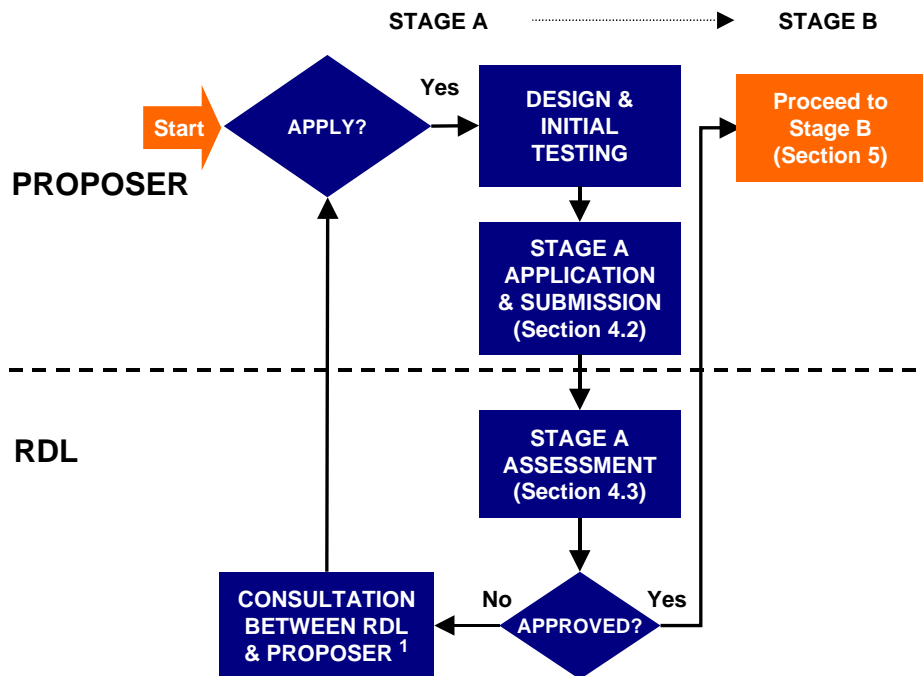

¹ Appropriate action may be agreed resulting in a revised submission

4.2 Application and Stage A submission

We need the following documents in your stage A submission please:

- Application form (if not already submitted).
- Application/'Stage A' fee (see www.robustdetails.com for current fees).
- 2 copies of each relevant sound test report and a completed copy of the Test Results Form (Form A2)
- 2 copies of the section details specifying the exact 'as-built' construction elements of the separating wall or floor structure(s) tested including all appropriate dimensions and product names/types tested*.
- 2 copies of the drawings showing flanking wall (external wall)/floor details in contact with separating wall/floor and relevant wall/ceiling lining finishes as tested*.
- 2 copies of the floor plans of the plots tested, including dimensions.

**Please refer to an existing published RD specification to identify the type and level of detail required.*

4.3 Stage A assessment

Upon receipt of the full submission and Stage A payment, we will review the sound test results and check them against our Test and Performance Requirements (document TR01).

If the test results meet or exceed our requirements, the robustness of the design will be assessed at the Standards Committee meeting (please also refer to [7.2.4](#)).

We will inform you of the outcome of the assessment, and if successful, you may then proceed to make a Stage B submission (see [Section 5](#)).

5 Stage B

5.1 Stage B process

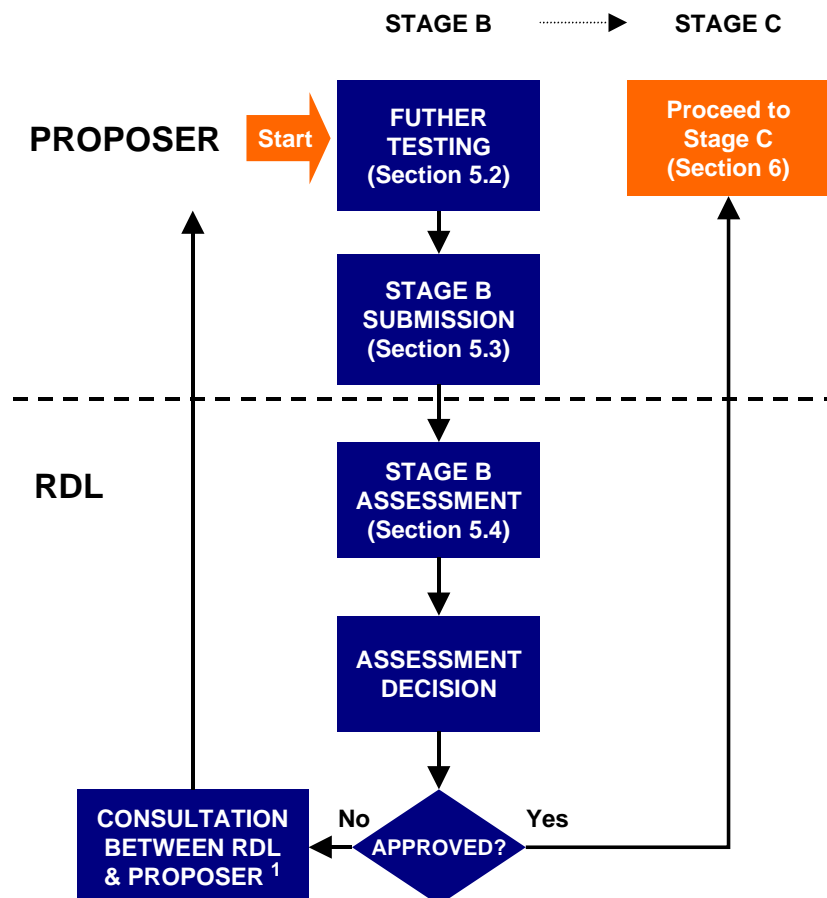

¹ Appropriate action may be agreed resulting in a revised submission

5.2 Stage B testing

You will need to:

- Arrange and finance further testing and ensure this is carried out in accordance with our Test & Performance Requirements (document TR01).
- Inform us of each test site, test date and the test body in advance of each test, so that we can, if we wish, carry out an inspection and/or observe testing. It also allows us to confirm that the selected structures are suitable to test, and gives us the opportunity to arrange to see the installation and clarify any queries raised at committee. Please give advance notice by e-mail (technical@robustdetails.com) or by sending us a completed copy of the Stage B Test Site Notification Form (Form B1) which is included in this pack.

- Select your test structures then “Test and declare” i.e. no pre-testing of the structures or “cherry-picking” of test results is allowed. Also, no 'rectification and retesting' is allowed. Form A2 requires you and the testing organisation to give signed confirmation that the selection and testing was carried out in accordance with our requirements.

5.3 Stage B test results

As and when your test results become available, please provide us with the following documentation:

- 2 copies of each relevant sound test report and a completed copy of the Test Results Form (Form A2).
- 2 copies of the section details specifying the exact 'as-built' construction elements of the separating wall or floor structure(s) tested including all appropriate dimensions and product names/types tested*.
- 2 copies of the drawings showing flanking wall (external wall)/floor details in contact with separating wall/floor and relevant wall/ceiling lining finishes as tested*.
- 2 copies of the floor plans of the plots tested, including dimensions.

**Please refer to an existing published RD specification to identify the type and level of detail required.*

5.4 Stage B assessment

Upon receipt of the full submission and Stage B payment, we will review all of the sound test results and check them against our Test and Performance Requirements (document TR01).

If the test results meet or exceed our requirements, the Standards Committee will reassess the robustness of the design in light of the additional test results, then make a final decision on the success of the application and its eligibility for credits under the Code for Sustainable Homes.

We will inform you of the outcome of the assessment, and if successful, your application will proceed to Stage C (see Section 6).

6 Stage C

6.1 Issue and publication of new/amended RDs

We will arrange for artwork to be prepared and consult you on the contents before publication.

Once published, we will make the new, or revised, RD specifications available to all existing subscribers and new purchasers. We will also make the necessary arrangements so that builders, developers and their agents can register their dwellings and use the new/amended RD as a means of complying with Requirement E1 of the Building Regulations (England and Wales).

We will invoice you for the Stage C fee once you have approved the artwork unless it has already been paid.

Where applicable, the detail will be added to the Code for Sustainable Homes table on the RDL web site.

RDL will also present proprietary details for assessment and inclusion in The Green Guide.

7 Frequently Asked Questions

7.1 Testing

7.1.1 The Test and Performance Requirements require the use of testing organisations which are independent from the Proposer for most of the tests. What do you mean by 'independent from the Proposer'?

A testing organisation would **not** be considered independent if it, or any of its nominees:

- had a professional or financial interest in the outcome of the assessment.
- was responsible for the design or construction of any of the work being tested in any capacity.
- was a member, officer or employee of a company or other body, which had a professional or financial interest in the work.
- was a partner or was in the employment of a person who had a professional or financial interest in the work.

7.2 Assessment process

7.2.1 Why do you need the option to carry out inspections on Stage B test structures or observe Stage B testing?

We may decide to carry out inspections of test structures or observe tests to ensure that the structure being tested was built exactly in accordance with the design that you submitted, and that no additional treatments or materials were applied that could enhance acoustic performance. It also gives us the opportunity to see the installation and clarify any queries raised at committee.

7.2.2 Who makes the final approval decision?

We have appointed independent technical experts to our Standards Committee and they make the final decision on the approval or otherwise of your application. In the event that they do not have the appropriate technical expertise to assess any aspect of your application, the Standards Committee has the power to engage the help of other independent experts as necessary.

7.2.3 Who decides whether a design is robust?

We have appointed independent technical experts to our Standards Committee and they make a judgement about robustness and take it into account when making the final approval decision. In the event that they do not have the appropriate technical expertise to judge the robustness of the design, the Standards Committee has the power to engage the help of other independent experts as necessary.

7.2.4 When will you assess our submission?

The Standards Committee meets on a quarterly basis and we publish its meeting dates and associated submission deadline dates on our web site (www.robustdetails.com). You will need to meet the relevant submission deadline if you want the Committee to assess your Stage A or Stage B submission at the associated meeting.

7.3 Financial

7.3.1 How much will it cost me for RDL's assessment and approval?

We publish a set of fees on our web site (www.robustdetails.com) and the appropriate fee is payable to RDL with your Stage A and Stage B submissions, and upon request for Stage C.

7.4 The Part E Robust Details Scheme

7.4.1 How can you be sure that built RDs will comply with Requirement E1 of the Building Regulations (England and Wales)?

Our assessment process aims to build in a safety margin so that, even if minor mistakes occur in the construction of an RD on site, acoustic performance should still exceed the performance requirements stated in Approved Document E.

We monitor the performance of each RD type in service by carrying out visual inspections and acoustic tests on a sample of built RDs in the market place. So far, we have exceeded the compliance rates agreed with government and set down as targets in our quality policy.

Please be aware that, if any RD type consistently fails to meet our performance target, we are obliged to take action. This may include suspension or even withdrawal of the RD type.